

Meistergram[®]
THE PERSONALIZATION PEOPLE™

M800 SERIES

USER MANUAL

PARTS IDENTIFICATION

PARTS IDENTIFICATION

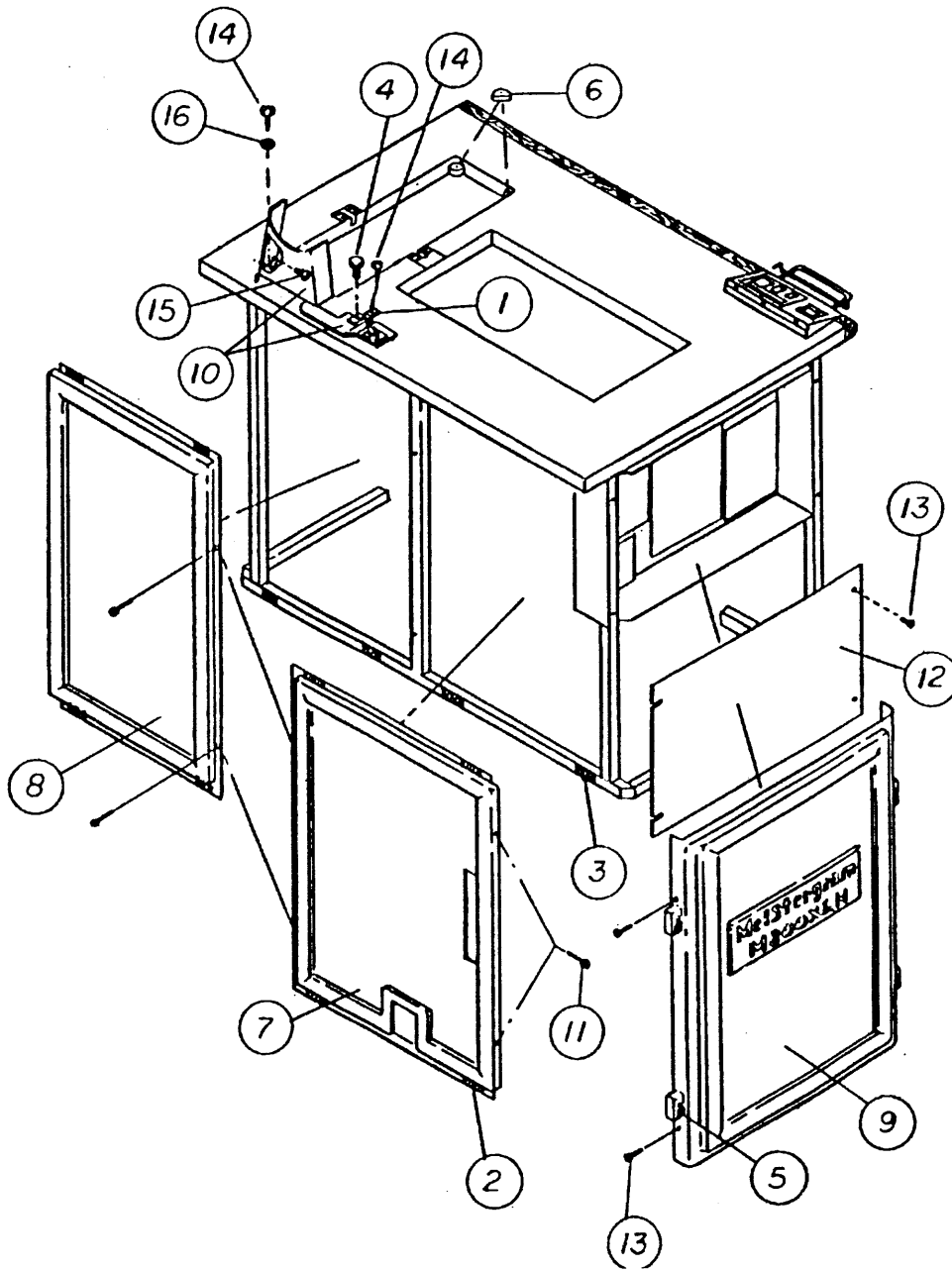

Frame Assembly 1 - fig. 1

PARTS IDENTIFICATION**PARTS LIST FOR THE M800XLM****FRAME ASSEMBLY**

ITEM	QUANTITY	PART NO.	DESCRIPTION
1	1	P520327	Bobbin Winder Guard Stop
2	3ft.	9P520005	Velcro Strip Hook
3	3ft.	9P520007	Velcro Strip Loop
4	1	P220501	Template Hold Thumbscrew
5	8	P620011	Tinnerman Clip
6	2	P620013	Rubber Corner Pad
7	1	P670006	Left Rear Panel
8	1	P670007	Right Rear Panel
9	2	P670008	Side Panel
10	1	ZP620300	Bobbin Winder Assembly
11	12	P670083	Screw #6 x 1/2 Type AB Phillips Head
12	1	P670835	Electric Enclosure Cover Plate
13	12	P840203	Screw #8-32 x 1/2 Self Tap
14	3	P840305	Wood Screw #7 x 3/4 Round Head
15	1	P840415	Screw #6-32 x 1/4 Pan Head
16	1	P840513	Washer #6 Nylon

PARTS IDENTIFICATION

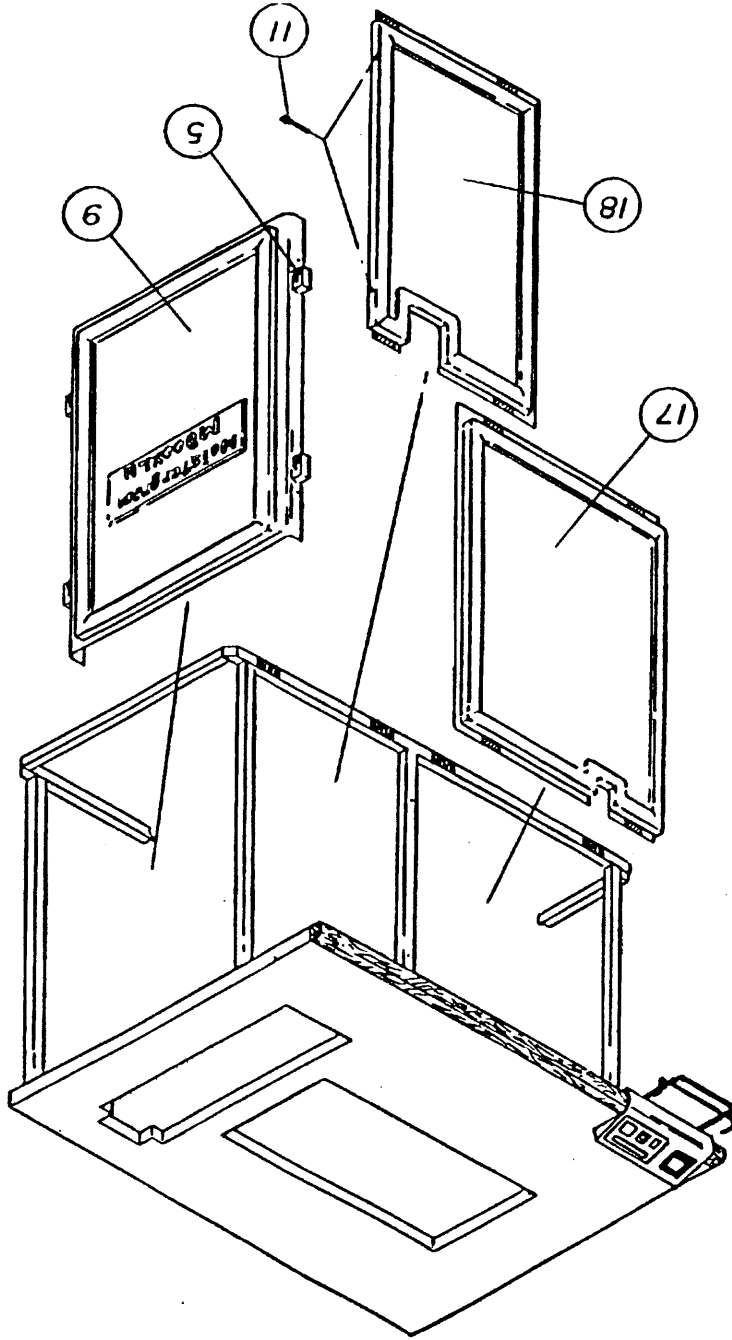

Frame Assembly 2 - fig. 2

PARTS IDENTIFICATION**FRAME ASSEMBLY**

ITEM	QUANTITY	PART NO.	DESCRIPTION
5	8	P620011	Tinnerman Clip
9	2	P670008	Side Panel
11	12	P670083	Screw #6 x 1/2 Type AB Phillips Head
17	1	P670004	Left Front Panel
18	1	P670005	Right Front Panel

PARTS IDENTIFICATION

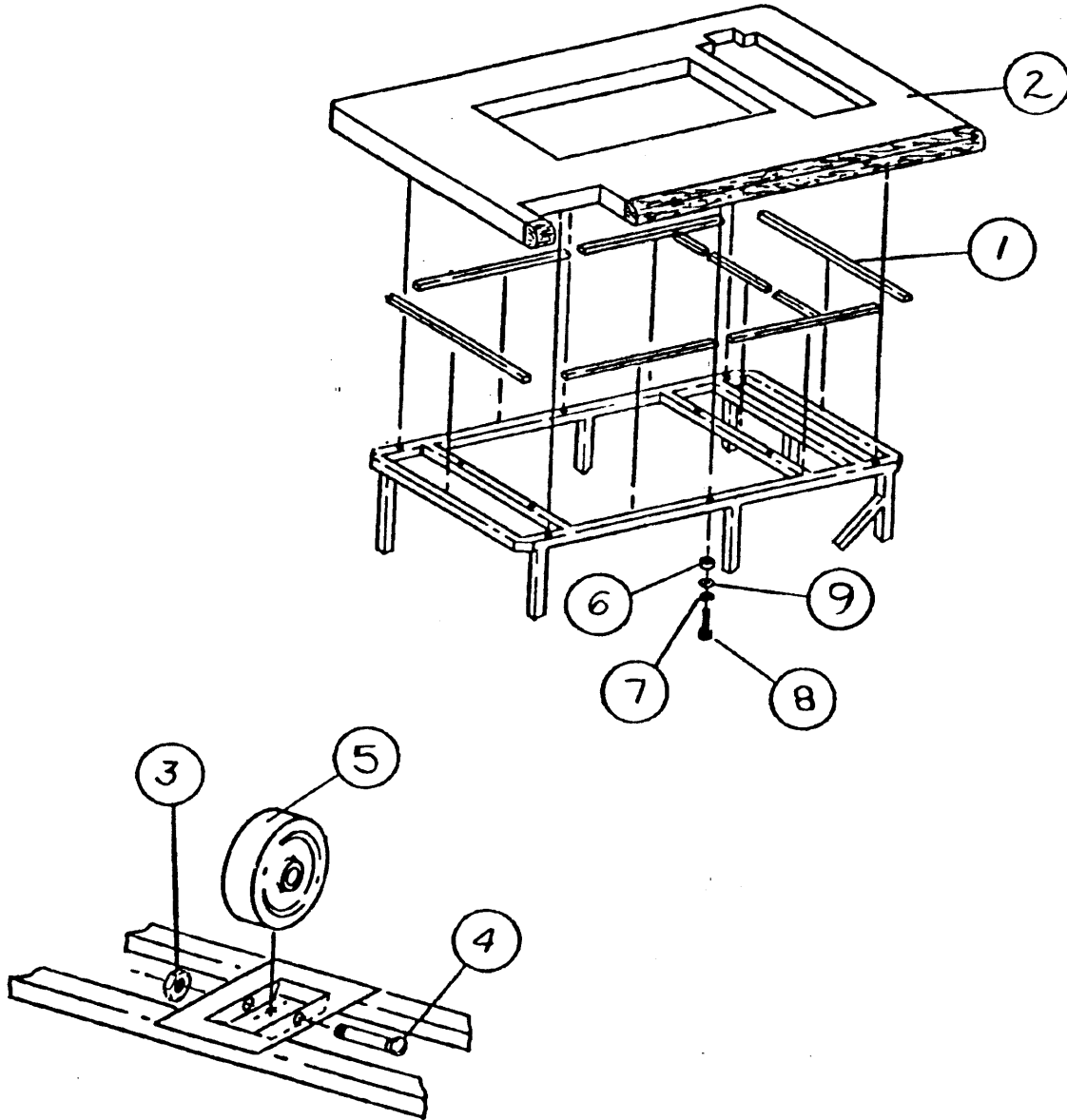

Frame Assembly 3 - fig. 3

PARTS IDENTIFICATION**FRAME ASSEMBLY**

ITEM	QUANTITY	PART NO.	DESCRIPTION
1	14ft.	9P520001	Adhesive Neoprene Strip
2	1	P670820	Table Top
3	2	P520064	Wheel Locknut
4	2	P520066	Wheel Axle
5	2	P670804	Wheel 4" Diameter
6	6	P840915	Rubber Grommet Z-399
7	14	P840580	Lockwasher 1/4
8	6	P840059	Screw 1/4-20 x 2-1/2 Socket Head
9	6	P840561	Flatwasher 5/16

PARTS IDENTIFICATION

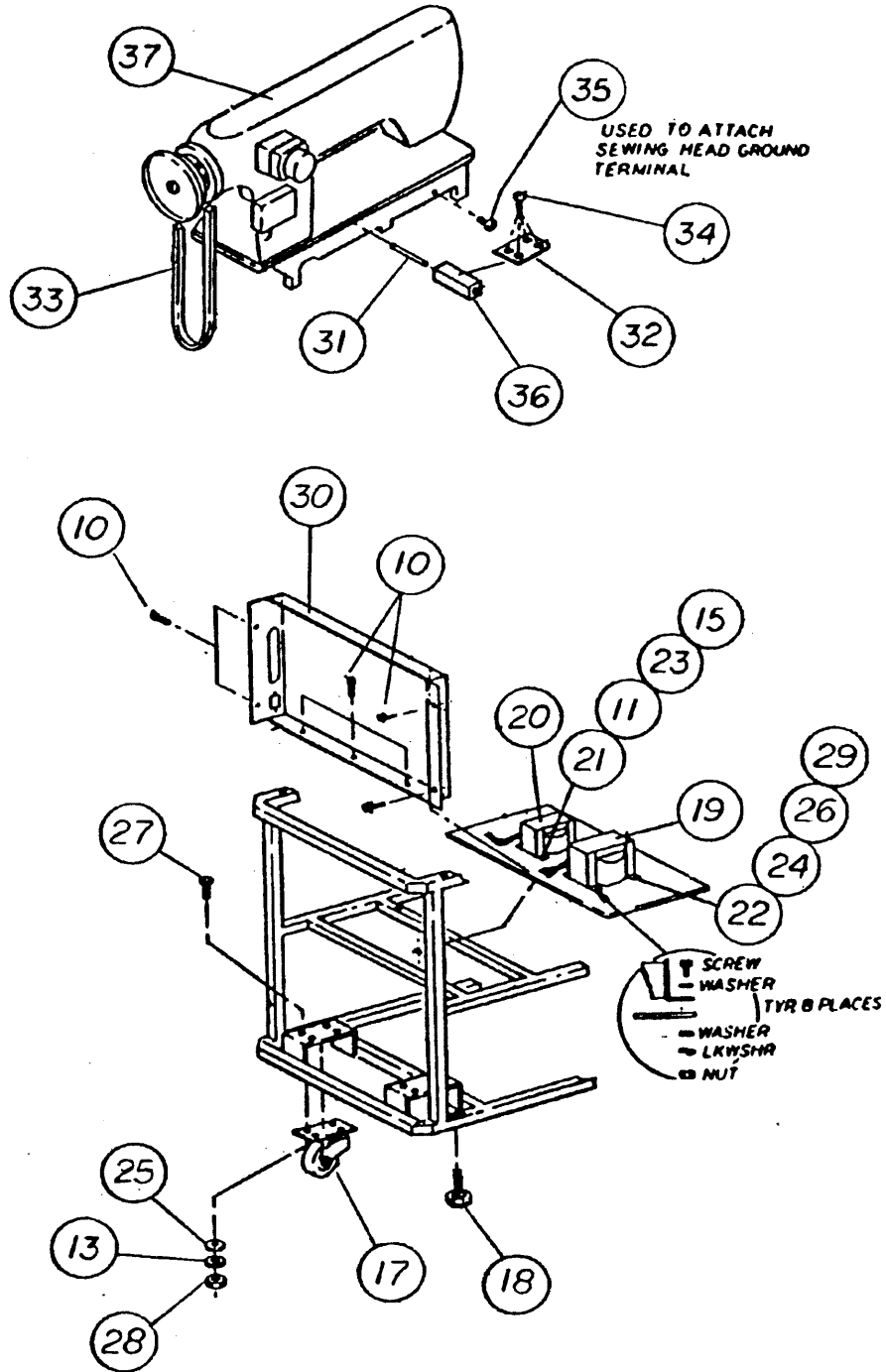

Frame Assembly 4 - fig. 4

PARTS IDENTIFICATION**FRAME ASSEMBLY**

ITEM	QUANTITY	PART NO.	DESCRIPTION
10	15	P840203	Screw #8-32 x 1/2 Hex Head Self Tap
11	10	P840520	Flatwasher #8
13	14	P840580	Lockwasher 1/4
15	6	P840730	Hex Nut #8-32
17	2	P670801	Caster
18	2	P670802	Leveling Foot
19	1	P680850	Control Transformer
20	1	P680855	Isolation Transformer
21	4	P840156	Screw #8-32 x 1/2 Hex Head
22	4	P840430	Screw #10-32 x 1/2 Pan Head
23	4	P840523	Lockwasher #8 Split
24	8	P840530	Flatwasher #10
25	8	P840540	Flatwasher 1/4
26	4	P840572	Lockwasher #10 Split
27	8	P840622	Bolt 1/4-20 x 5/8 Hex Head
28	8	P840710	Hex Nut 1/4-20
29	4	P840740	Hex Nut #10-32
30	1	P670830	Electronics Enclosure Assembly
31	2	P514003	Hinge Pin
32	2	P520024	Hinge Cover Plate
32	2	P520024	Hinge Cover Plate
33	1	P820046	V Belt 46"
34	8	P840148	Screw #6-32 x 3/8 Phillips Flat Head
35	1	P840188	Screw #6-32 x 1/2 Pan Head
36	2	P840914	Hinge Pin Grommet
37	1	ZP660000	Sewing Head Assembly

PARTS IDENTIFICATION

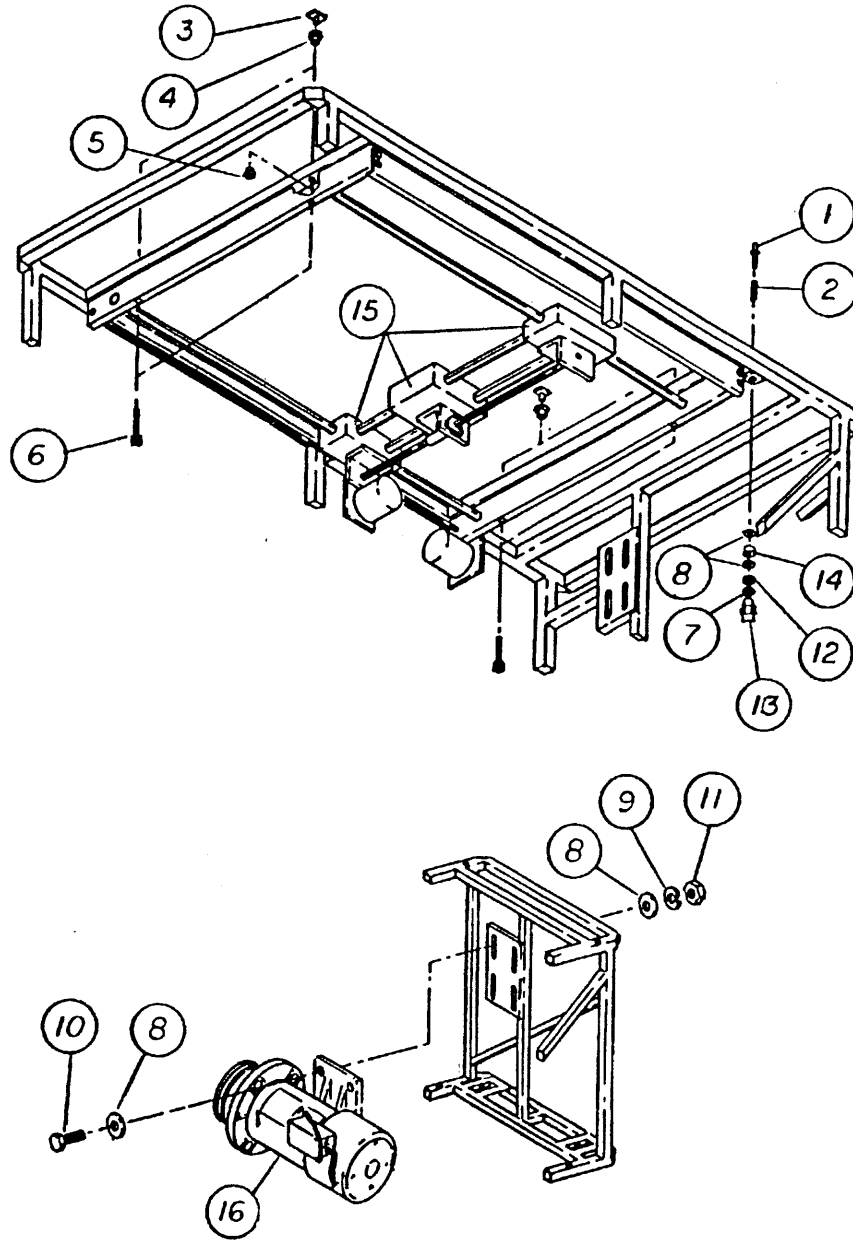

Frame Assembly 5 - fig. 5

From the library of: Diamond Needle Corp

PARTS IDENTIFICATION**FRAME ASSEMBLY**

ITEM	QUANTITY	PART NO.	DESCRIPTION
1	1	P520072	Head Locking Screw
2	1	P520074	Head Locking Spring
3	4	P520406	T-Nut 1/4-20 x 7/16 Plain Base
4	4	P520408	Grommet
5	4	P520509	Well-Nut
6	4	P840062	Screw 1/4-20 x 3 Socket Head
7	1	P840504	Lockwasher 1/4 Internal Tooth
8	10	P840561	Flatwasher 5/16
9	4	P840582	Lockwasher 5/16 Split
10	4	P840603	Bolt 5/16-18 x 1 Hex Head
11	4	P840707	Hex Nut 5/16-18
12	1	P840710	Hex Nut 1/4-20
13	1	P840785	Fingernut 4 Prong Black
14	1	P840915	Rubber Grommet Z-399
15	1	ZP670400	Pantograph Assembly
16	1	ZP680600	D.C. Motor Assembly

PARTS IDENTIFICATION

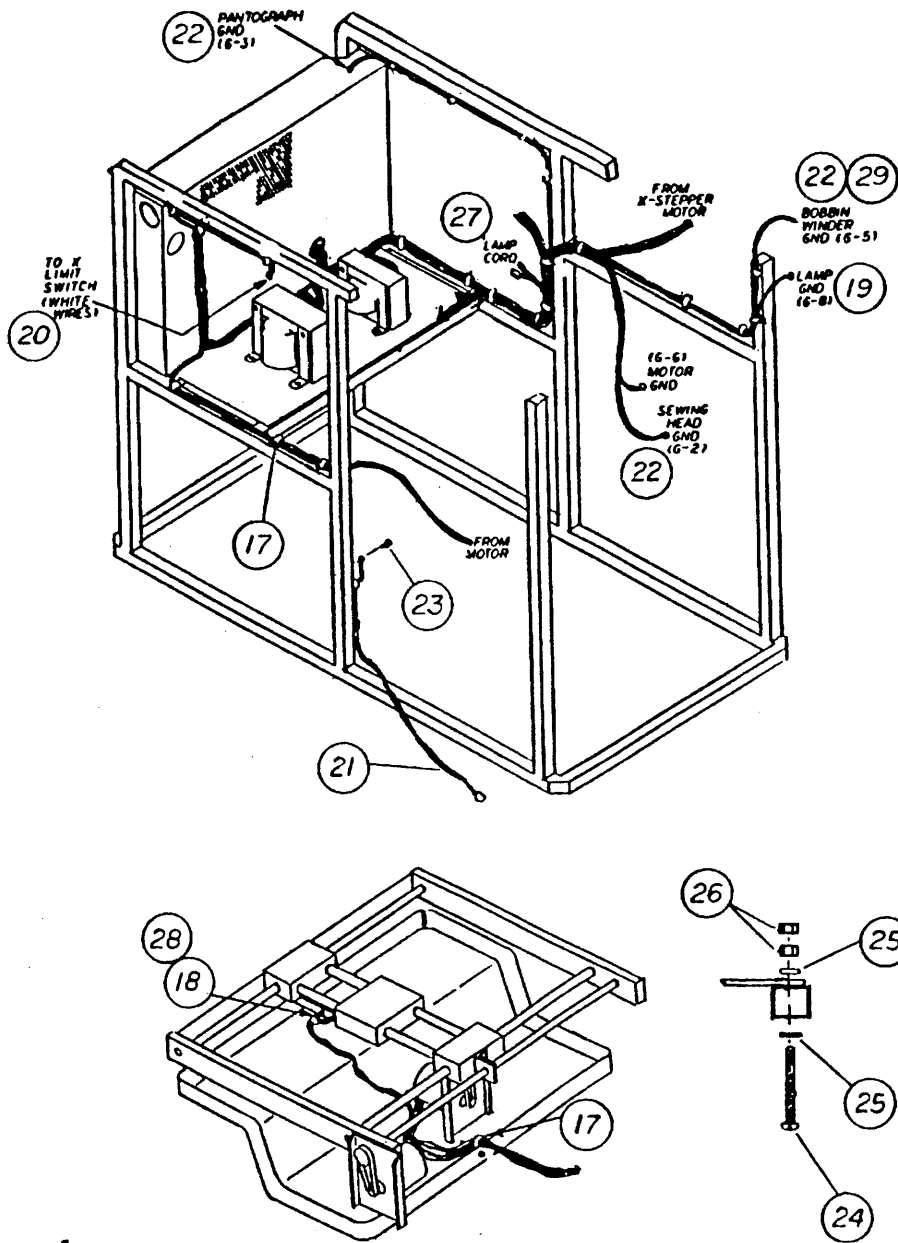

Frame Assembly 6 - fig. 6

PARTS IDENTIFICATION**FRAME ASSEMBLY**

ITEM	QUANTITY	PART NO.	DESCRIPTION
17	23	P530237	Push Mount Cable Tie
18	1	P620105	Nylon Spacer
19	1	P680726	Lamp Ground Wire
20	1	P680740	X-Y Limit Switch Wire Harness
21	1	P680741	Static Mat Ground Wire
22	1	P680742	System Ground Harness
23	1	P840150	Screw #6-32 x 1/4 Round Head
24	2	P840440	Screw #10-32 x 2 Slot Pan Head
25	4	P840535	Flatwasher #10 Brass
26	4	P840742	Hex Nut 10-32 Brass
27	1	ZP680743	Lamp Cord Assembly
28	1	P312027	Cable Tie 5"
29	1	P820511	Ring Terminal #6 16-14 Ga

PARTS IDENTIFICATION

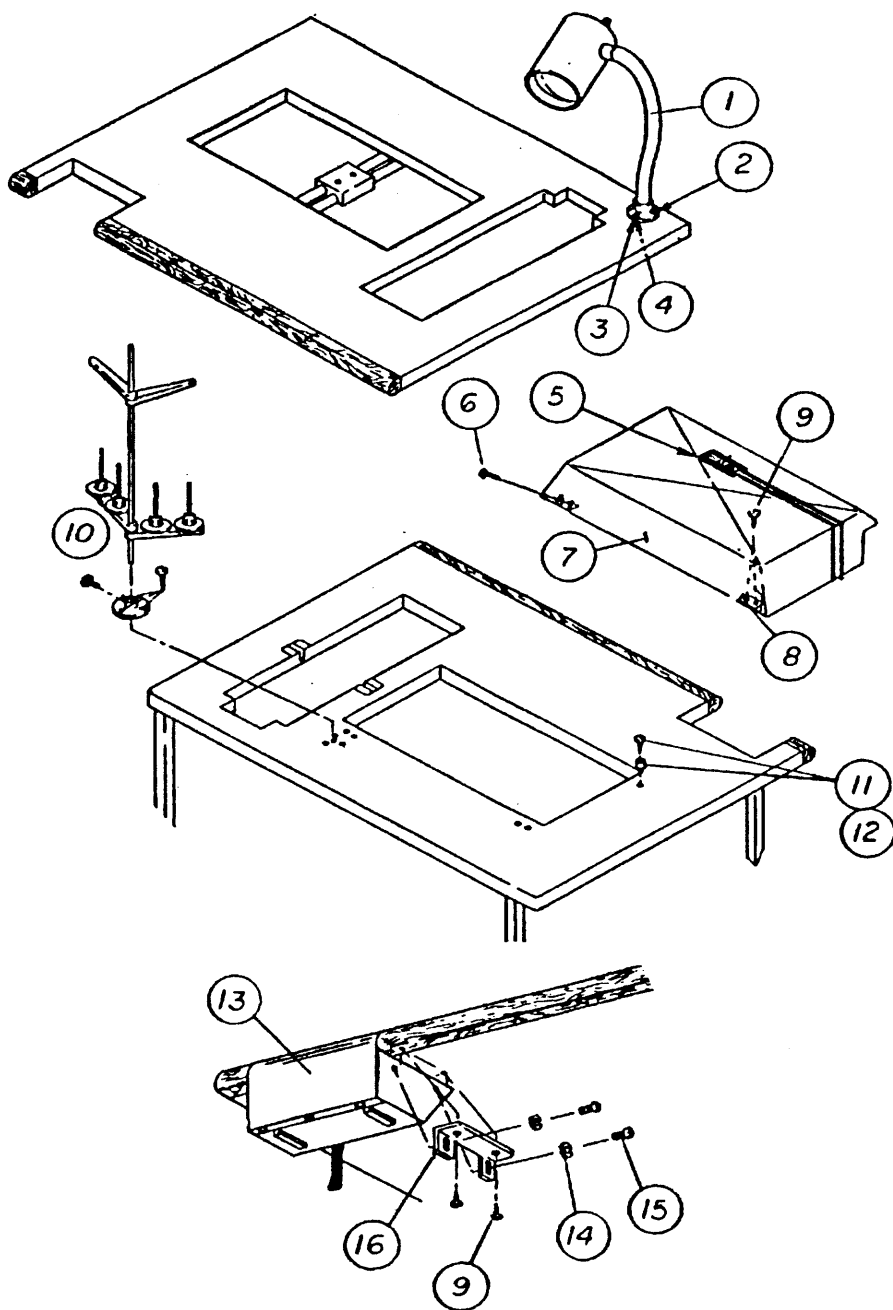

Table Top Assembly 1 - fig. 7

PARTS IDENTIFICATION**TABLE TOP ASSEMBLY**

ITEM	QUANTITY	PART NO.	DESCRIPTION
1	1	ZP670950	Lamp-Connector Assembly
2	2	P840313	Wood Screw #10 x 3/4 Round Head
3	1	P848432	Screw #10-32 x 2 Slot Pan Head
4	2	P840740	Hex Nut #10-32
5	1	P896006	Pantograph Cover Decal
6	4	P840642	Pop Rivet 3/16 x 3/8
7	1	P670915	Pantograph Cover
8	2	P520011	Pantograph Cover Hinge
9	8	P840305	Wood Screw #7 x 3/4 Slot Round Head
10	1	P520030	Thread Stand w/Mounting Hardware
11	1	P840905	Rubber Stop 3/8 x 1/4 Black
12	1	P840302	Wood Screw #4 x 3/8
13-T	1	ZP680500	Control Console Assembly
13-D	1	ZP681500	Control Console Assembly
14	4	P840572	Lockwasher #10 Split
15	4	P840420	Screw #10-32 x 3/8 Pan Head
16	2	P670910	Console Mounting Bracket

- T Indicates parts for use with machine supplied with cassette tape drive.
 -D Indicates parts for use with machine supplied with disk drive.

PARTS IDENTIFICATION

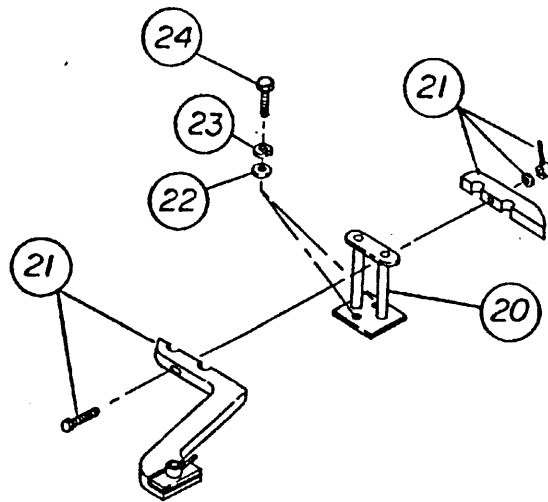
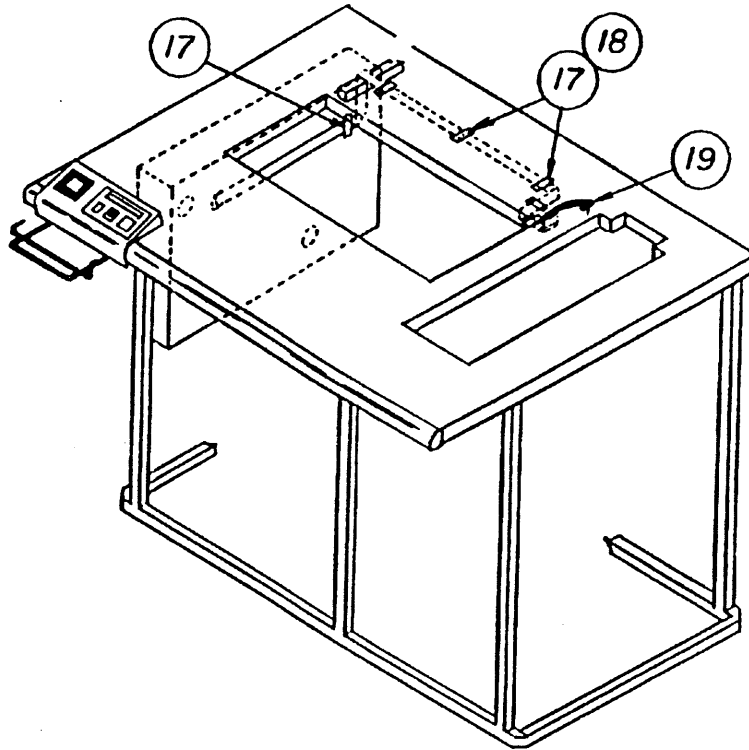
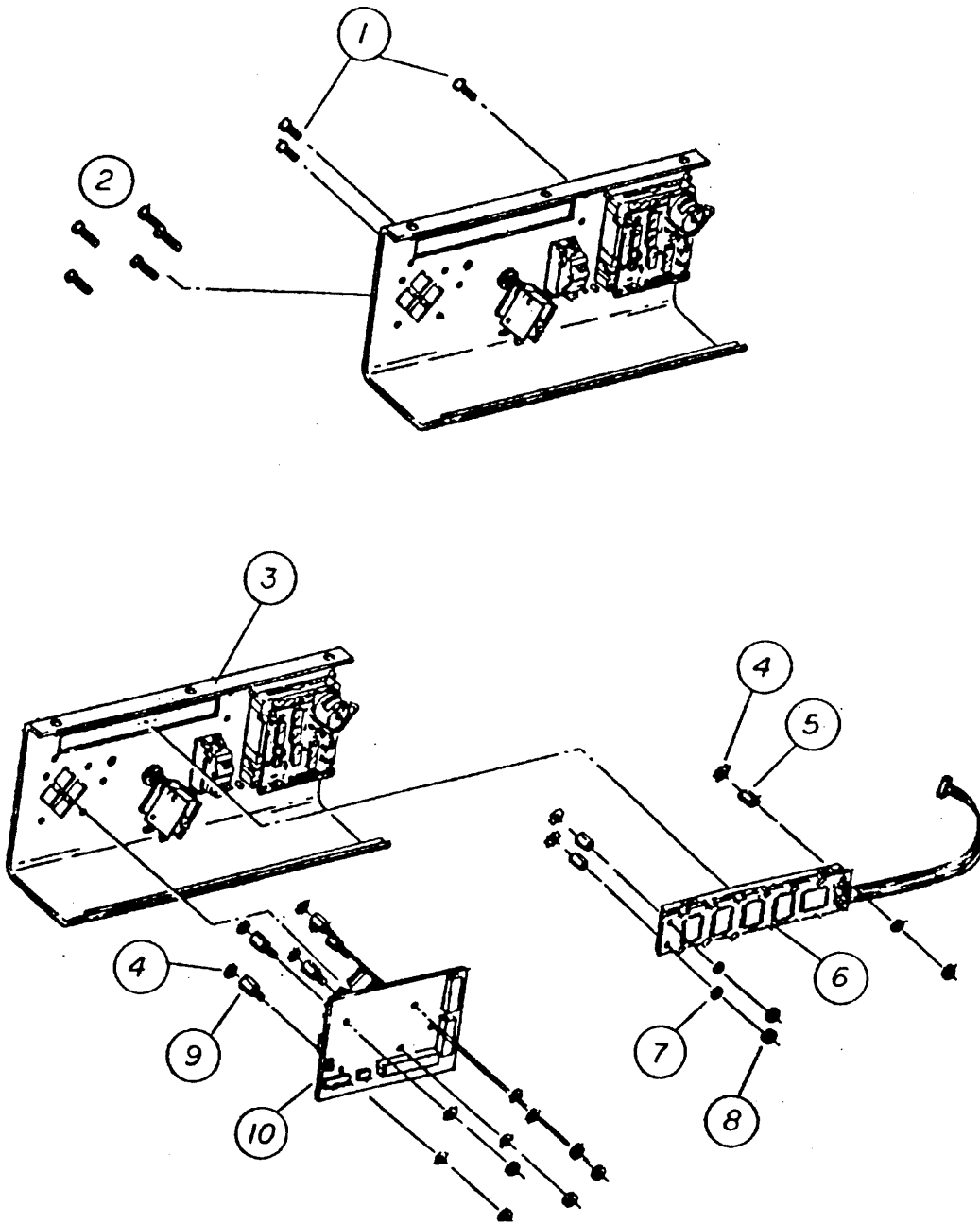

Table Top Assembly 2 - fig. 8

PARTS IDENTIFICATION**TABLE TOP ASSEMBLY**

<u>ITEM</u>	<u>QUANTITY</u>	<u>PART NO.</u>	<u>DESCRIPTION</u>
17	6	P520109	Flat Cable Clamp
18	5	P840347	Wood Screw #6 x 1/2 Flathead
19	1	P680745	Head Interface Ribbon Cable
20	1	P520501	Hoop Arm Base
21	1	ZP620500	Hoop Arm Assembly
22	2	P840561	Flatwasher 5/16
23	2	P840582	Lockwasher 5/16 Split
24	2	P840601	Bolt 5/16-18 x 3/4

PARTS IDENTIFICATION



Control Console Assembly 1 - fig. 9

From the library of: Diamond Needle Corp

PARTS IDENTIFICATION**CONTROL CONSOLE ASSEMBLY**

ITEM	QUANTITY	PART NO.	DESCRIPTION
1	1	P840402	Screw #4-40 x 5/8 Slot Flat Head
2	5	P840390	Screw #4-40 x 3/8 Slot Flat Head
3-T	1	P680501	Console Panel
3-D	1	P680515	Console Panel
4	13	P840502	Lockwasher #4 External Tooth
5	3	P680514	Standoff #4 = 40 x 1/4 Nylon
6	1	ZP680550	Liquid Crystal Display Assembly
7	3	P840512	Nylon Washer #4
8	8	P840715	Hex Nut #4-40
9	5	P680511	Standoff #4-40 x 7/16 M/F
10	1	P680510	Hoop Control PC Board

- T Indicates parts for use with machine supplied with cassette tape drive.
 -D Indicates parts for use with machine supplied with disk drive.

PARTS IDENTIFICATION

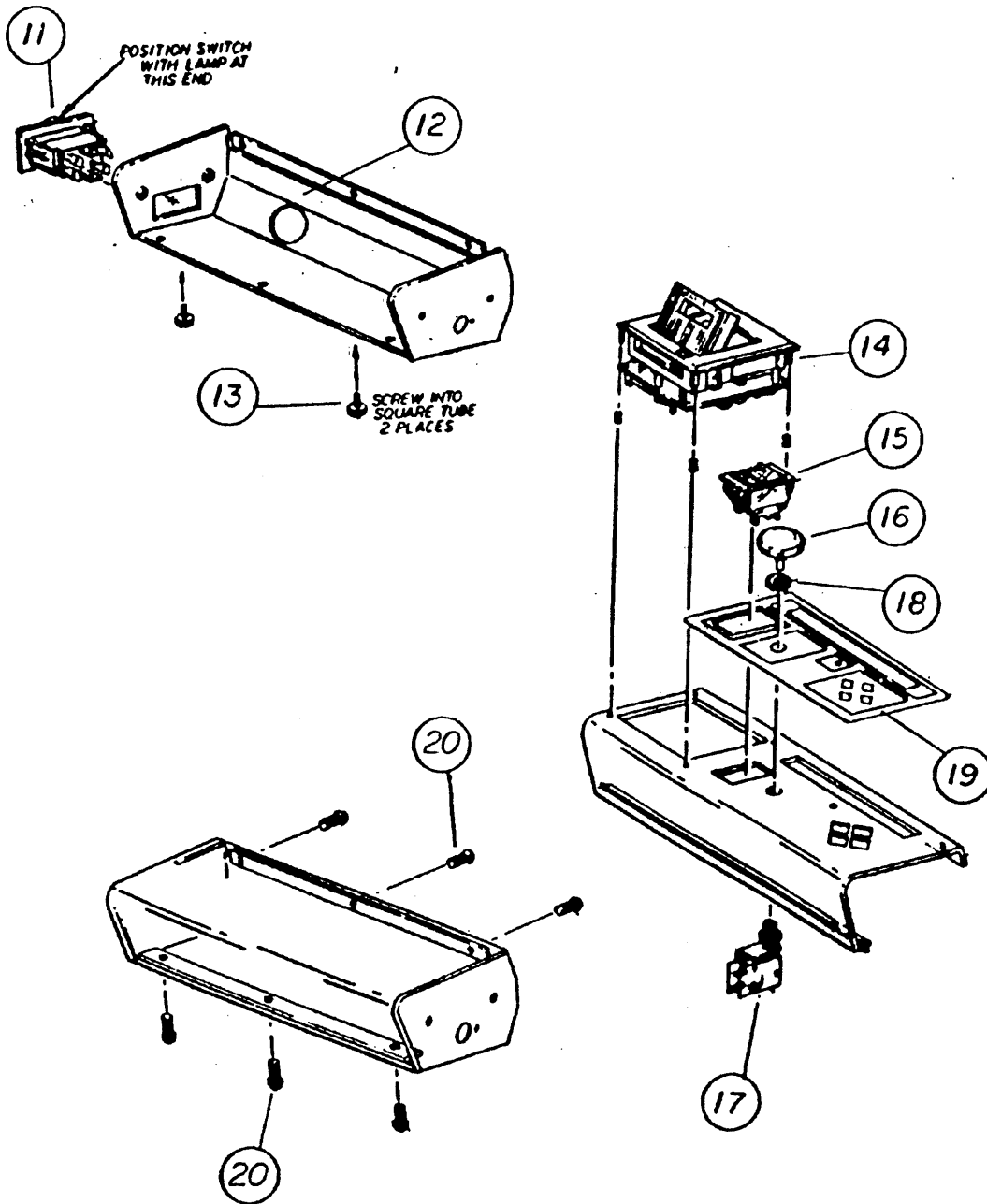

Control Console Assembly 2 - fig. 10

PARTS IDENTIFICATION**CONTROL CONSOLE ASSEMBLY**

ITEM	QUANTITY	PART NO.	DESCRIPTION
11	1	P520012	Main Power Switch
12	1	P680502	Console Enclosure
13	2	P220501	Thumbscrew
14-T	1	P530125	Tape Drive w/Mounting Hardware
15	1	P680505	Motor Breaker Switch
16	1	P520020	Red Button
17	1	P520018	Emergency Stop Switch
18	1	P520019	Stop Switch Locknut
19-T	1	P896001	Console Panel Decal
19-D	1	P686017	Console Panel Decal
20	6	P680512	Screw #8-32 x 3/8/Phillips Dec Head

- T Indicates parts for use with machine supplied with cassette tape drive.
 -D Indicates parts for use with machine supplied with disk drive.

PARTS IDENTIFICATION

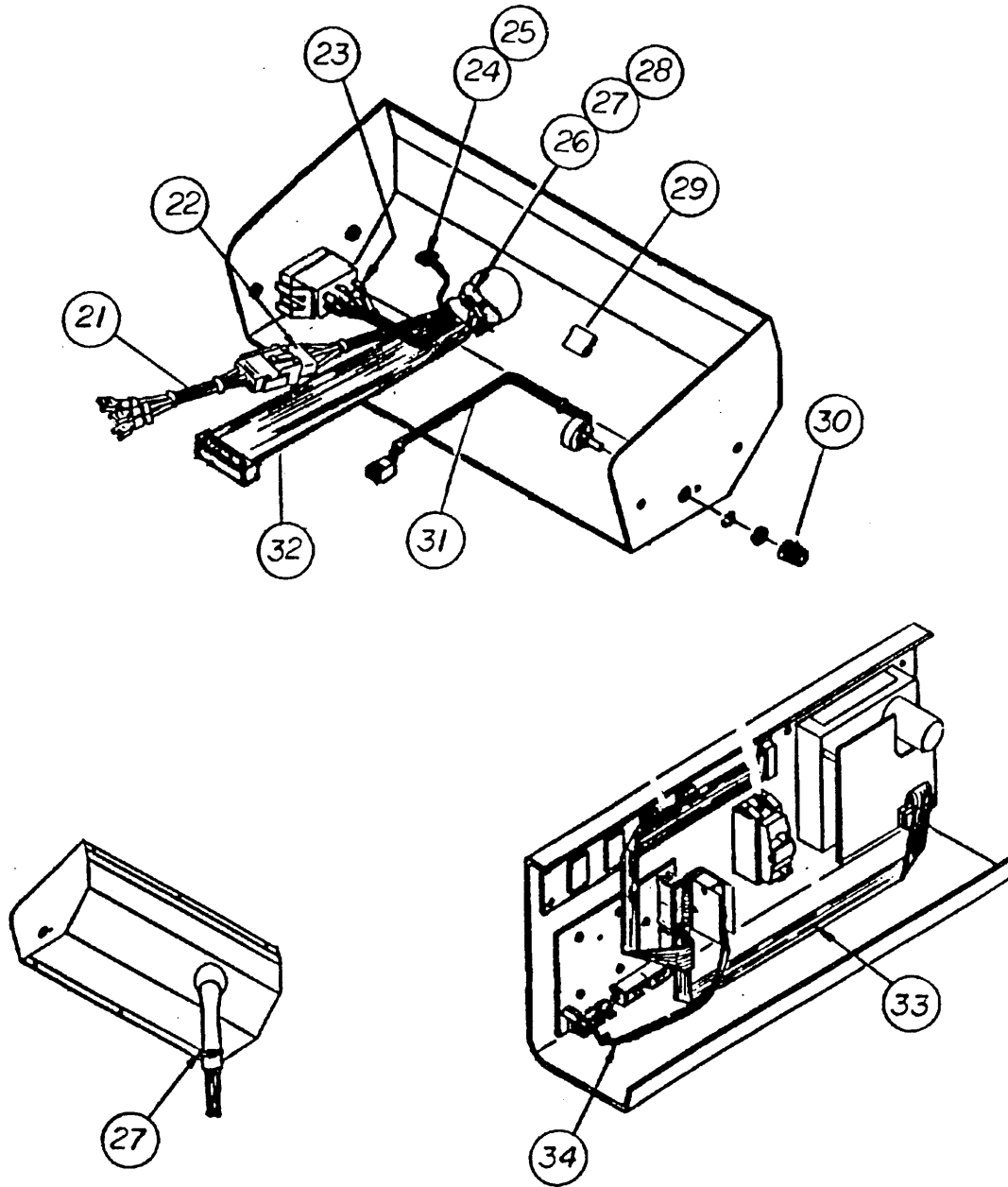

Control Console Assembly 3 - fig. 11

PARTS IDENTIFICATION**CONTROL CONSOLE ASSEMBLY**

ITEM	QUANTITY	PART NO.	DESCRIPTION
21	1	P680711	Safety Switch Wire Harness
22	1	P680710	DC Drive Safety Switch Harness
23	1	P680750	Power Switch Wire Harness
24	1	P680714	Console Ground Wire
25	1	P840150	Screw #6-32 x 1/4 Phillips Round Head
26	1ft.	9P680515	Zipper Tubing
27	2	P312027	Cable Tie
28	1	P530237	Push Mount Cable Tie
29	1	P520085	Flat Cable Clip
30	1	P680530	Plastic Knob Assembly
31	1	P680717	View Adjust Wire Harness
32	1	P680730	SBC to Console Ribbon Cable
33-T	1	P680712	Hoop to Tape Ribbon Cable
33-D	1	P680728	Connector Block for Disk
34	1	P680716	Emergency Stop Switch Wire Harness

-T Indicates parts for use with machine supplied with cassette tape drive.

-D Indicates parts for use with machine supplied with disk drive.

PARTS IDENTIFICATION

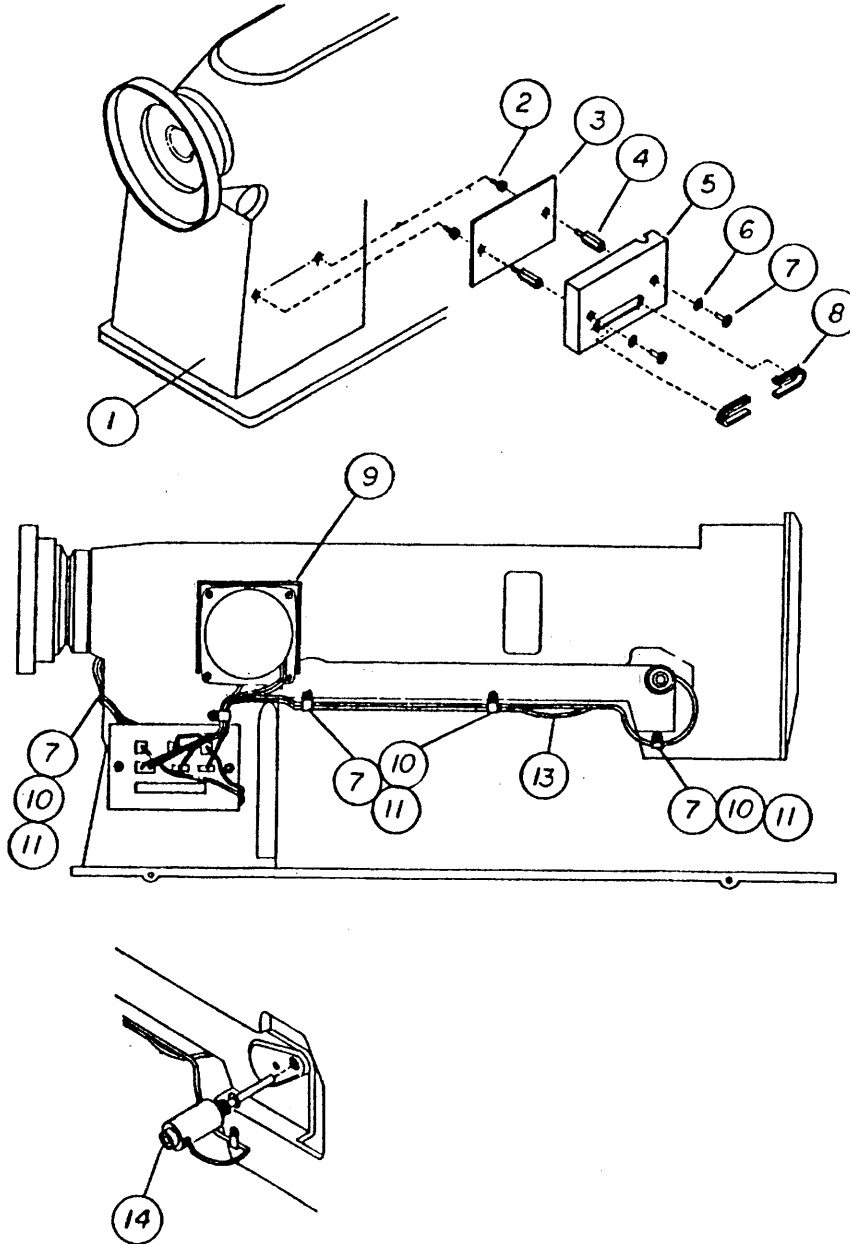

Sewing Head Assembly 1 fig. 12

PARTS IDENTIFICATION**SEWING HEAD ASSEMBLY**

ITEM	QUANTITY	PART NO.	DESCRIPTION
1	1	P660001	Sewing Head
2	2	P413035	Standoff #6-32 x 1/4 M/F
3	1	P680250	Head Interface PC Board
4	2	P614003	Standoff #6-32 x 3/4 M/F
5	1	P614038	Interface Card Cover
6	2	P840511	Lockwasher #6 Internal Tooth
7	7	P840410	Screw #6-32 x 3/8 Slot Pan Head
8	2	P840916	Rubber Grommet Z-633
9	1	P413022	Stitch Width Cover
10	5	P840510	Flatwasher #6
11	4	P820056	Cable Clip 1/8"
12	1	P820057	Cable Clip 1/4"

PARTS IDENTIFICATION

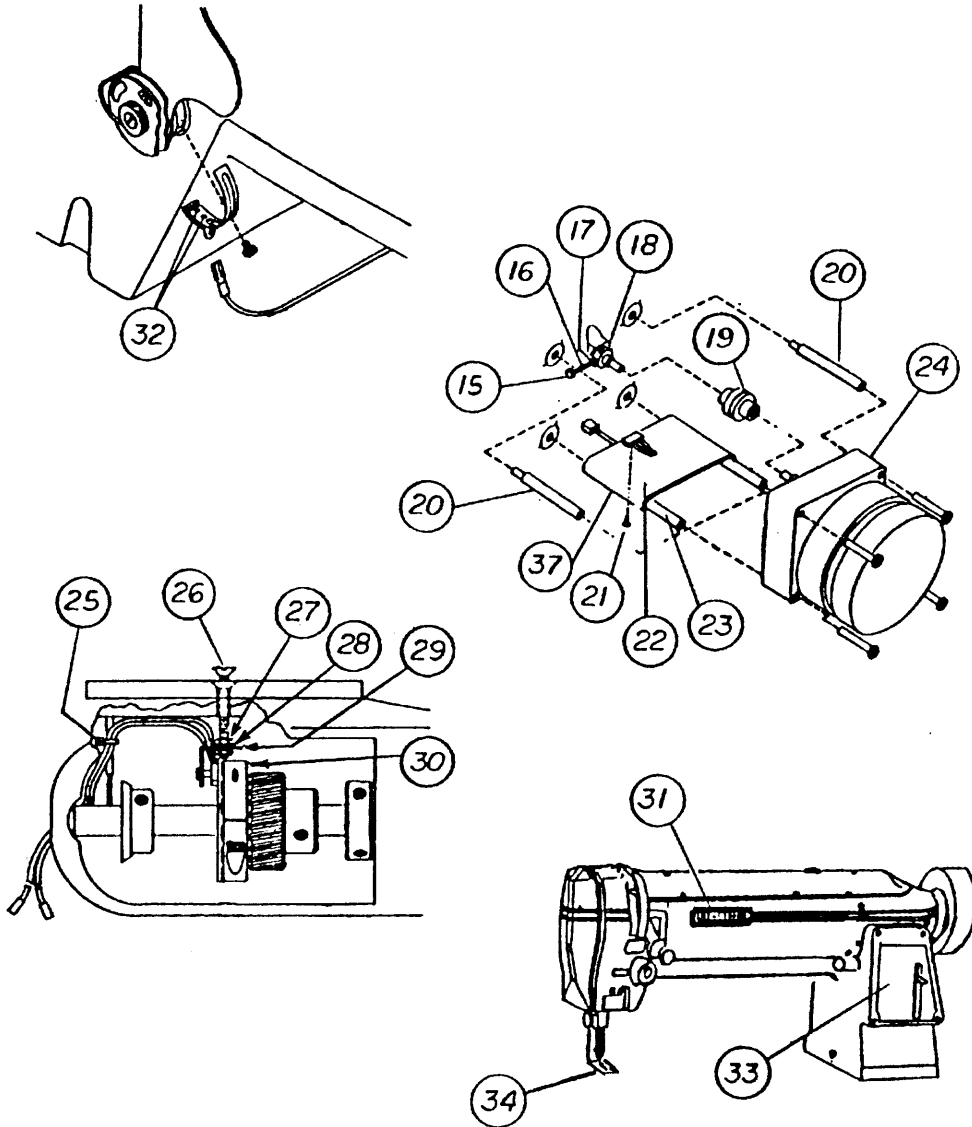

Sewing Head Assembly 2 - fig. 13

PARTS IDENTIFICATION**SEWING HEAD ASSEMBLY**

ITEM	QUANTITY	PART NO.	DESCRIPTION
13	1	ZP614015	Thread Sensor Wire Harness
14	1	ZP614010	Tension Release Solenoid Assembly
15	1	P413018	Magnet
16	1	P840405	Screw #4-40 x 3/4 Slot Pan Head
17	1	P840715	Hex Nut #4-40
18	1	P413780	Collar #35534
19	1	P312013	Stitch Width Motor Coupling
20	2	P413004	Support Post 2"
21	1	P840401	Screw #4-40 x 1/8 Slot Pan Head
22	1	ZP614025	Limit Sensor Assembly
23	2	P413003	Support Post 1-3/4"
24	1	ZP614050	Stitch Width Motor Assembly
25	1	P312027	Cable Tie
26	1	P840122	Screw #8-32 x 1-1/2 Flathead
27	2	P840730	Hex Nut #8-32
28	1	P840523	Lockwasher #8 Split
29	1	ZP614040	PT/NPS Pick-up Assembly
30	1	ZP614030	PT/NPS Sender Assembly
31	1	P896007	Sewing Head Decal
32	2	P614067	Screw M3-.5 x 5mm Nylon
33	1	P896003	Stitch Width Decal
34	1	P413012	Presser Foot
35	1	P413820	Hook Assembly
36	1	P413830	Bobbin Case (not pictured)

PARTS IDENTIFICATION

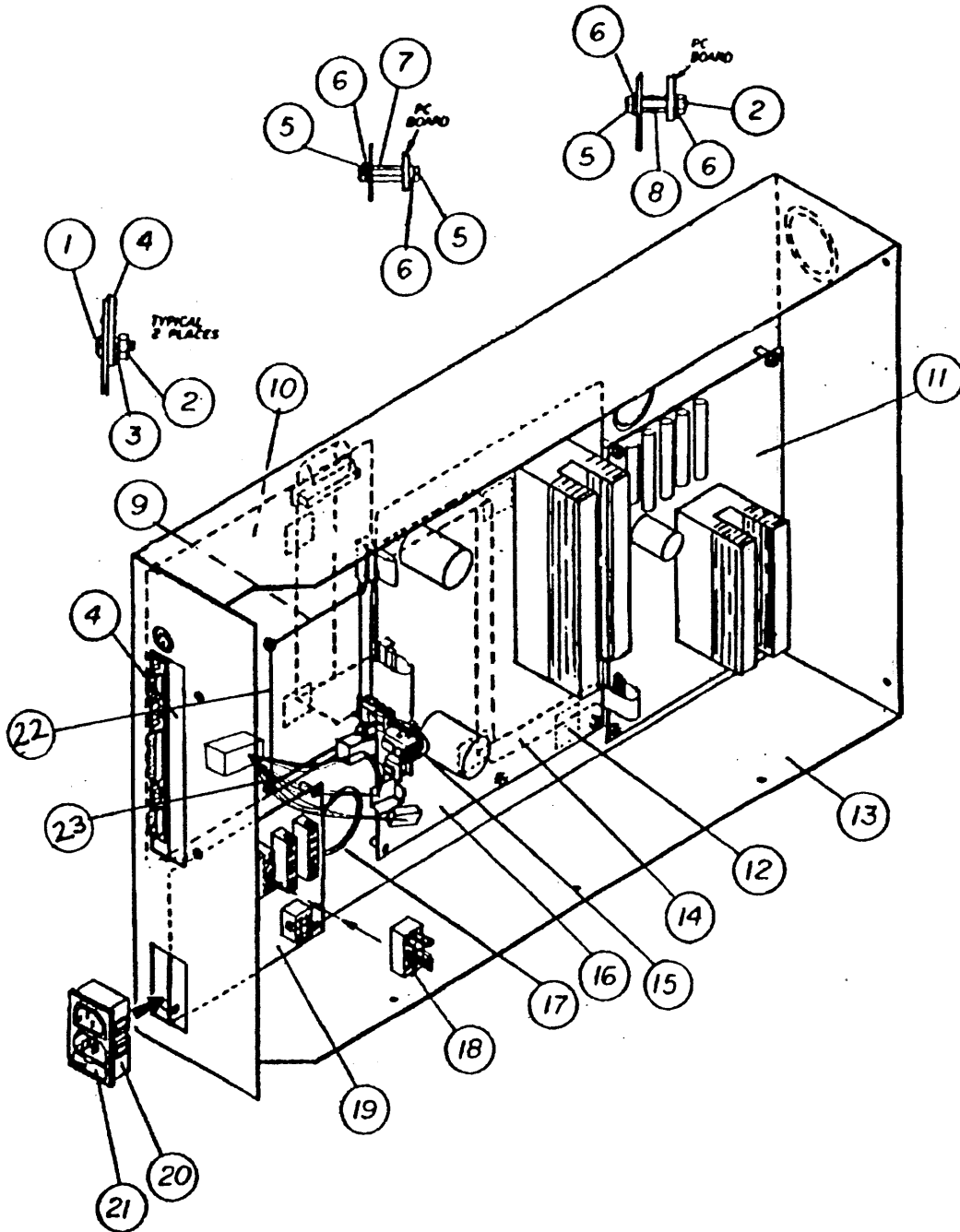

Electronics Enclosure Assembly - fig. 14

PARTS IDENTIFICATION**ELECTRONICS ENCLOSURE ASSEMBLY**

ITEM	QUANTITY	PART NO.	DESCRIPTION
1 - T	2	P840410	Screw #6-32 x 3/8 Slot Pan Head
2	25	P840725	Hex Nut #6-32 Small Pattern
3 - T	2	P840509	Lockwasher #8 Split
4 - T	1	P670806	Disc Expansion Cover Plate
5	31	P840415	Screw #6-32 x 1/4 Slot Pan Head
6	54	P840511	Lockwasher #6 Split
7	4	P530132	Standoff #6-32 x 1/2
8	23	P680721	Standoff #6-32 x 1/2 M/F
9	1	P680725	Ribbon Cable SBC to CE Board
10	1	ZP680110	Single Board Computer Assembly
11	1	P680300	Motor Drive PC Board
12	5	P520085	Flat Cable Clip
13	1	P670830	Electronics Enclosure
14	1	P680720	Ribbon Cable D.C. Drive to SBC
15	1	P680715	SBC to CE Jumper Harness
16	1	P680200	Control Electronics PC Board
17	2ft.	9P530200	Grommet Material
18	1	P680722	110V Jumper Block
19	1	P680400	Power Junction PC Board
20	1	P680410	Fused Power Connector
21	1	P530807	Fuse 5A 250V Slow Blow
22 - D	1	P680125	Floppy Controller
23 - D	1	P680758	Floppy Power Harness

PARTS IDENTIFICATION

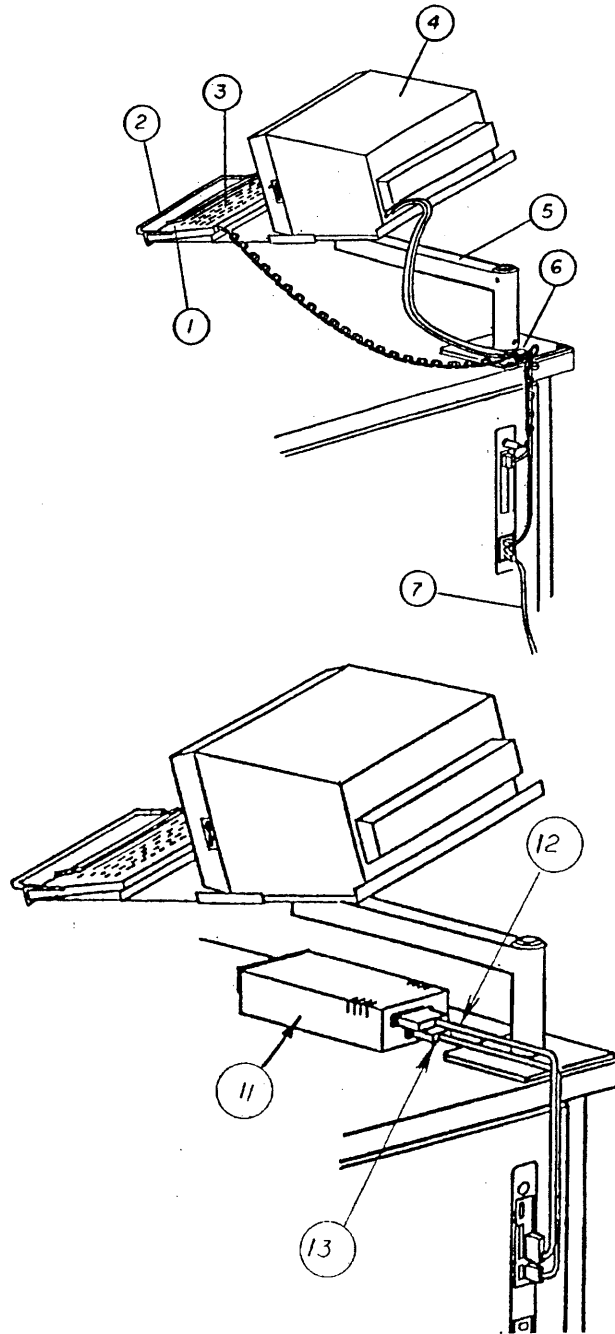

Accessories - fig. 15

PARTS IDENTIFICATION**ACCESSORIES**

ITEM	QUANTITY	PART NO.	DESCRIPTION
1	2	P896002	Keyboard/Monitor Decal
2	1	P670010	Keyboard Rack
3	1	P670020	Keyboard
4	1	P670015	Monitor
5	1	ZP670100	Motor Arm Assembly
6	1	P670911	Stick-on Cable Clamp
7	1	P670105	Power Cord
8	1	B16011	Anti-Static Mat (not pictured)
9	1	B66215	Machine Tool Kit (not included)
10	1	B7160	Instructional Manual (not pictured)
11-D	1	ZP680150	Disk Drive Assembly
12-D	1	P680757	Drive Control Cable 37 Pin
13-D	1	P680756	Key Interface Cable 15 Pin

-D Indicates parts required for use with machine supplied with disk drive.

PARTS IDENTIFICATION**XL SEWING HEAD TOP COVER, FACE PLATE, THREAD GUIDE & THREAD TENSION**

REF.	QUANTITY	PART NO.	DESCRIPTION
6031	2	P413225	Throat Plate Screw
8060	1	P413240	Screw
10551	1	P413298	Needle Bar Connecting Link Rear Guard
10650	2	P413385	Screw
10675	1	P413405	Tension Bracket
10678	2	P413408	Tension Release Lever
10679	2	P413409	Tension Release Lever Screw
10682	1	P413411	Thread Guide Upper
10685	3	P413414	Screw
10691	2	P413420	Thread Disk
10692	1	P413421	Tension Release Washer
10694	1	P413423	Thread Controller Disk
10695	1	P413424	Disk Screw
10697	3	P413426	Tension Thumb Nut
10789	1	P413489	Tension Stud
10791	1	P413491	Tension Bracket Pin
10792	1	P413492	Thread Controller Stud
10793	1	P413493	Tension Release Plunger
11006	1	P413503	Thread Guide, Top Cover
11160	1	P413525	Thread Guide, Middle
12048	1	P413529	Tension Release Spring
13076	1	P413541	Nut For Upper Thread Guide
15004	1	P413551	Top Cover Gasket
15007	7	P413553	Screw
15025	1	P413557	Take-up Lever Guard
15035	1	P413565	Face Plate
15036	1	P413566	Face Plate Hinge
15037	1	P413567	Face Plate Spring
15038	1	P413568	Rubber Plug
15039	8	P413569	Screw
15055	1	P413571	Screw
15062	1	P413578	Thread Retainer
35504	1	P413750	Top Cover

PARTS IDENTIFICATION**XL SEWING HEAD TOP COVER, FACE PLATE, THREAD GUIDE & THREAD TENSION (Continued)**

<u>REF.</u>	<u>QUANTITY</u>	<u>PART NO.</u>	<u>DESCRIPTION</u>
35556	1	P413805	Throat Plate
35557	1	P413806	Throat Plate Locating Pin
35578	1	P413842	Spring
35582	1	P413846	Tension Release Lever Rod
35585	1	P413849	Thread Guide, Lower
35612C	1	P614065	Thread Break Sensor Assembly
90000	1	P614010	Tension Release Solenoid Assembly

NOTES

PARTS IDENTIFICATION**XL SEWING HEAD ARM SHAFT & THREAD TAKE-UP**

REF.	QUANTITY	PART NO.	DESCRIPTION
10504	1	P413250	Balance Wheel
10506	1	P413252	Arm Shaft Oil Packing Stop Screw
10520	1	P413266	Needle Bar Crank
10521	1	P413267	Screw
10522	1	P413268	Set Screw
10523	1	P413269	Needle Bar Connecting Link Stud
10524	4	P413270	Set Screw
10528	1	P413274	Needle Bar Connecting Link
10562	1	P413310	Arm Shaft Bushing, Front
10563	1	P413311	Arm Shaft Bushing, Front Washer
10566	3	P413314	Set Screw
10571	3	P413319	Set Screw
10576	1	P413324	Screw
10577	1	P413325	Balance Wheel Adjusting Screw
10579	1	P413327	Set Screw
10725	4	P413437	Oil Felt
10726	1	P413438	Oil Wick
10728	1	P413439	Oil Wick
10729	1	P413440	Oil Wick
10764	1	P413464	Set Screw
10766	2	P413466	Set Screw
10771	1	P413471	Lifting Eccentric
11012	1	P413509	Oil Wick
11042	1	P413515	Oil Wick
13081	1	P413543	Oil Felt
13423PB	1	P413549	Stitch Length Indicator
15013	1	P413555	Take-up Lever Hinge Stud
15026	1	P413559	Take-up Lever Drive Stud
15033	1	P413563	Oil Wick for Arm Shaft
15034	1	P413564	Oil Wick Holder
15038	1	P413568	Rubber Plug
17011	1	P413601	Arm Shaft
17012	1	P413602	Arm Shaft Bushing, Middle
17013	1	P413603	Arm Shaft Bushing, Rear

PARTS IDENTIFICATION**XL SEWING HEAD ARM SHAFT & THREAD TAKE-UP (Continued)**

<u>REF.</u>	<u>QUANTITY</u>	<u>PART NO.</u>	<u>DESCRIPTION</u>
17014	1	P413604	Arm Shaft Bushing, Collar
17017	1	P413607	Arm Shaft Gear, Spiral
17018	1	P413608	Set Screw
17019	1	P413609	Set Screw
18003	1	P413650	Thread Take-up Lever
35505	1	P413751	Feed Fork Collar
90001	1	P614030	PT/NPS Sender Assembly
90002	1	P614040	PT/NPS Pick Up Assembly

NOTES

PARTS IDENTIFICATION

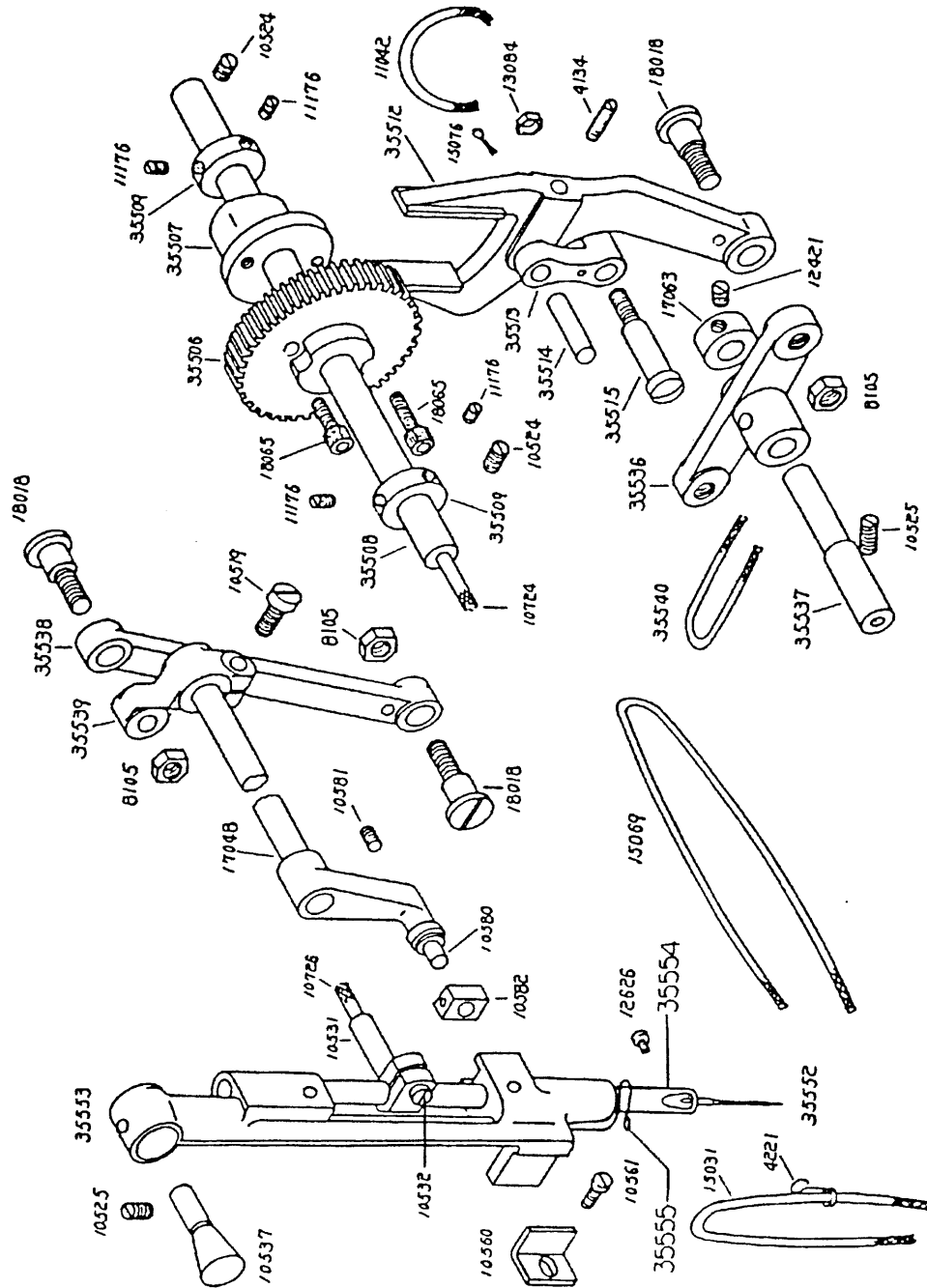

XL Sewing Head Needle Bar - fig. 18

PARTS IDENTIFICATION**XL SEWING HEAD NEEDLE BAR**

REF.	QUANTITY	PART NO.	DESCRIPTION
4134	1	P413205	Screw
4221	1	P413213	Oil Wick Clamp
8105	3	P413247	Nut
10519	1	P413265	Screw
10524	2	P413270	Set Screw
10525	2	P413271	Set Screw
10531	1	P413278	Needle Bar Connecting Stud
10532	1	P413279	Screw
10537	1	P413283	Needle Bar Rock Frame Hinge Stud
10560	1	P413308	Needle Bar Rock Frame Position Bracket
10561	1	P413309	Screw
10580	1	P413328	Needle Bar Rock Frame Slide Block Stud
10581	1	P413329	Set Screw
10582	1	P413330	Needle Bar Rock Frame Slide Block
10724	1	P413436	Oil Wick
10726	1	P413438	Oil Wick
11042	1	P413515	Oil Wick
11176	4	P413527	Set Screw
12421	1	P413533	Set Screw
12626	1	P413535	Needle Screw
13084	1	P413545	Nut
15031	1	P413561	Oil Wick
15069	1	P413581	Oil Wick
15076	1	P413585	Cotter Pin
17048	1	P413638	Needle Bar Rock Frame Shaft
17063	1	P413641	Collar
18018	3	P413660	Hinge Screw
18065	2	P413699	Screw
35506	1	P413752	Stitch Width Drive Gear
35507	1	P413753	Stitch Width Cam
35508	1	P413754	Stitch Width Cam Shaft
35509	2	P413755	Shaft Collar
35512	1	P413758	Stitch Width Cam Follower

PARTS IDENTIFICATION**XL SEWING HEAD NEEDLE BAR (Continued)**

<u>REF.</u>	<u>QUANTITY</u>	<u>PART NO.</u>	<u>DESCRIPTION</u>
35513	1	P413759	Pivot Link
35514	1	P413760	Shaft for Pivot Link
35515	1	P413761	Shoulder Screw For Pivot Link
35536	1	P413782	Pivot Connecting Bracket
35537	1	P413783	Pivot Shaft
35538	1	P413784	Needle Bar Rock Frame Shaft Crank Connection
35539	1	P413785	Needle Bar Rock Frame Shaft Crank
35540	1	P413786	Oil Wick
35552	1	P413799	Needle
35553	1	P413802	Needle Bar Frame
35554	1	P413803	Needle Bar
35555	1	P413860	Needle Bar Thread Guide

NOTES

PARTS IDENTIFICATION

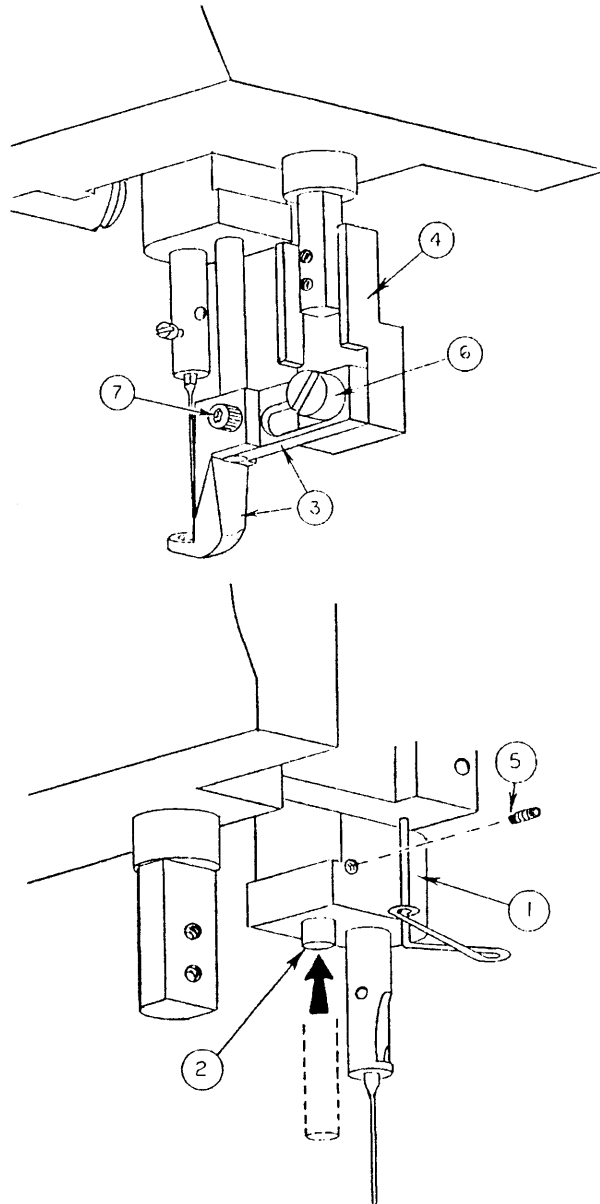

Jump Foot - fig. 19

From the library of: Diamond Needle Corp

PARTS IDENTIFICATION**XL SEWING HEAD NEEDLE BAR & PRESSER BAR COMPONENTS**

<u>ITEM</u>	<u>QUANTITY</u>	<u>PART NO.</u>	<u>DESCRIPTION</u>
1	1	P642510	Jump Foot Needle Bar Frame/Rod Assembly
2	1	P642501	Jump Foot Bar
3	1	P642503	Jump Foot
4	1	P642502	Link
5	1	P660005	Set Screw for Bar (Nylon Tip) #4-40x1/4
6	1	P840485	Shoulder Screw for Link #8- 32X1/8
7	1	P840045	Socket Head Screw for Foot #4-40x3/16

PART IDENTIFICATION

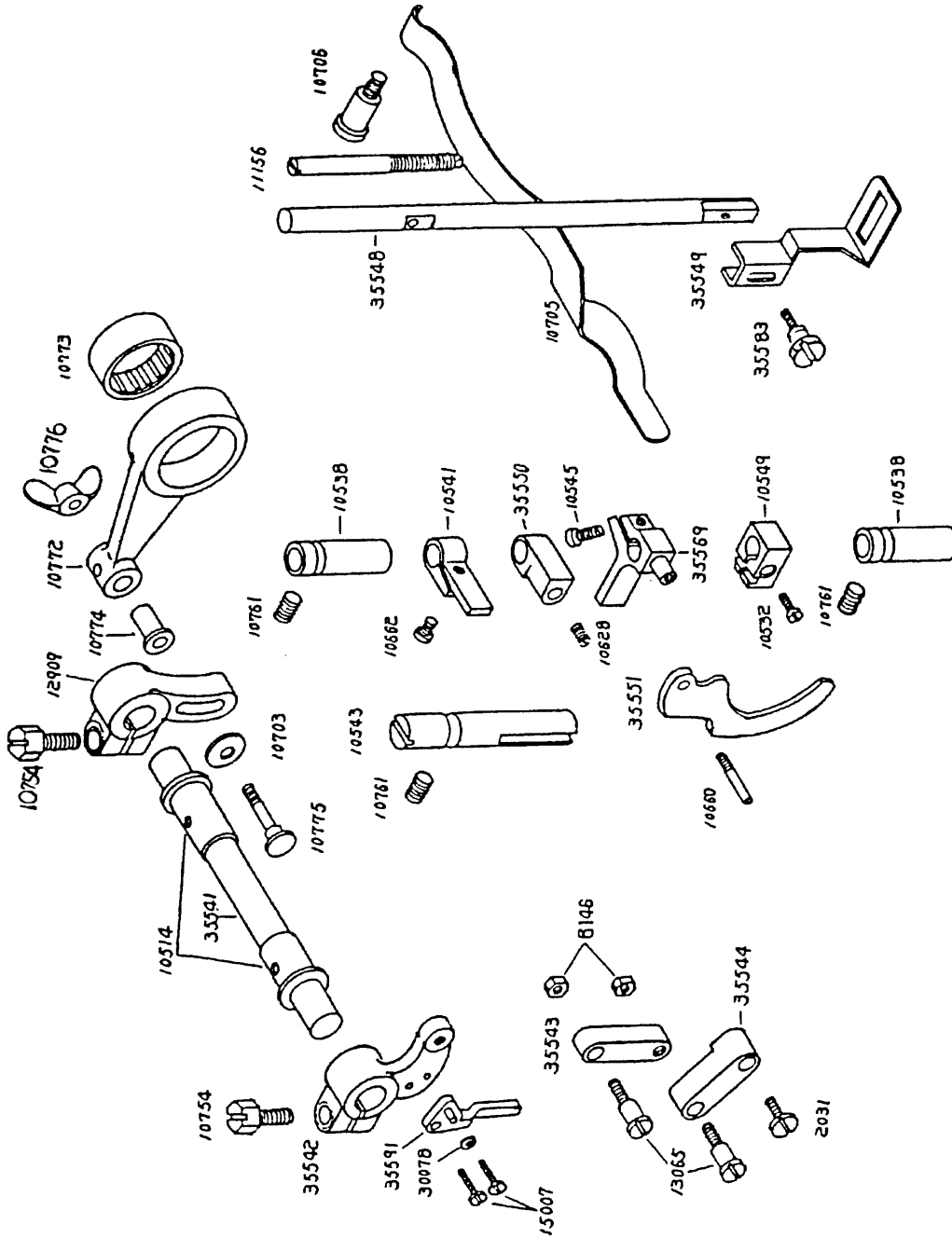

Presser Bar & Components - fig. 20

PARTS IDENTIFICATION**XL SEWING HEAD PRESSER BAR & COMPONENTS**

REF.	QUANTITY	PART NO.	DESCRIPTION
2031	1	P413203	Screw
8146	2	P413249	Nut
10514	2	P413260	Sleeve Bearing
10532	1	P413279	Screw
10538	2	P413284	Presser Bar Bushing
10541	1	P413287	Presser Position Guide Bracket
10543	1	P413289	Presser Bar Position Guide
10545	1	P413291	Screw
10549	1	P413295	Presser Bar Spring Bracket
10628	1	P413365	Set Screw
10660	1	P413390	Screw
10662	1	P413392	Screw
10703	1	P413432	Washer
10705	1	P413434	Presser Bar Spring, Flat
10706	1	P413435	Support Screw for Presser Bar Spring
10754	2	P413454	Screw
10761	3	P413461	Set Screw
10772	1	P413472	Eccentric/Cam
10773	1	P413473	Needle Bearing
10774	1	P413474	Sleeve
10775	1	P413475	Shoulder Stud
10776	1	P413476	Wing Nut
11156	1	P413523	Presser Bar Spring Regulating Screw
12909	1	P413537	Presser Bar Eccentric Cam Link, Left
13065	2	P413539	Connecting Link Shoulder Screw
15007	2	P413553	Screw
30078	1	P413725	Nut
35541	1	P413788	Eccentric Cam Link Shaft
35542	1	P413787	Presser Bar Eccentric Cam Link, Right
35543	1	P413789	Presser Bar Lift Brkt Conn. Link Upper
35544	1	P413790	Presser Bar Lift Brkt Conn. Link Lower
35548	1	P413795	Presser Bar
35549	1	P413012	Presser Foot
35550	1	P413797	Presser Bar Lifter Stud

PARTS IDENTIFICATION**XL SEWING HEAD PRESSER BAR & COMPONENTS (Continued)**

<u>REF.</u>	<u>QUANTITY</u>	<u>PART NO.</u>	<u>DESCRIPTION</u>
35551	1	P413798	Presser Bar Lifter Lever
35569	1	P413815	Presser Bar Lifter Bracket
35583	1	P413847	Pinch Screw
35591	1	P413855	Lifter

NOTES

PARTS IDENTIFICATION

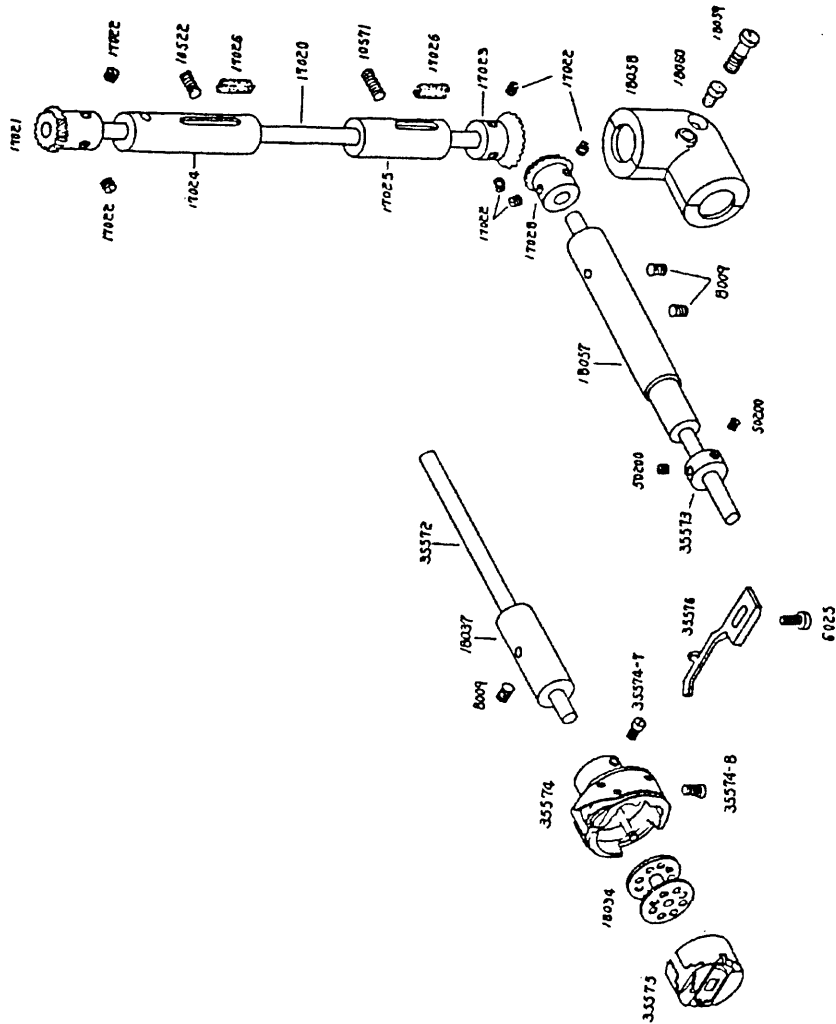

Sewing Head Connecting Rod, Lower Shaft & Hook - fig. 21

From the library of: Diamond Needle Corp

PARTS IDENTIFICATION**XL SEWING HEAD CONNECTING ROD, LOWER SHAFT & HOOK**

REF.	QUANTITY.	PART NO.	DESCRIPTION
6025	1	P413220	Bobbin Case Pos. Finger Screw
8009	3	P413230	Set Screw
10522	1	P413268	Set Screw
10571	1	P413319	Set Screw
17020	1	P413610	Arm Shaft Upright
17021	1	P413611	Arm Shaft Upright Spiral Gear
17022	6	P413612	Set Screw
17023	1	P413613	Arm Shaft Upright Gear, Lower
17024	1	P413614	Arm Shaft Upright Bushing, Upper
17025	1	P413615	Arm Shaft Upright Bushing, Lower
17026	2	P413616	Oil Felt
17028	1	P413618	Lower Shaft Gear Spiral
18034	1	P413670	Bobbin
18037	1	P413674	Hook Shaft Bushing, Rear
18057	1	P413695	Lower Shaft Bushing
18058	1	P413696	Lower Gear Cover Complete
18059	1	P413697	Pinch Screw
18060	1	P413698	Lower Gear Cover Sealing Screw
35572	1	P413818	Hook Drive Shaft
35573	1	P413819	Hook Drive Shaft Thrust Collar
35574	1	P413820	Rotating Hook Assembly Complete
35574-7	1	P413827	Hook Screw
35574-8	1	P413828	
35575	1	P413830	Bobbin Case Assembly Complete
35576	1	P413840	Hook Supporting Plate
50200	2	P413861	Set Screw

PARTS IDENTIFICATION**XL SEWING HEAD STITCH WIDTH REGULATION & COMPONENTS**

REF.	QUANTITY	PART NO.	DESCRIPTION
4135	2	P413206	Lock Nut
8042	1	P413237	Set Screw
8103	1	P413245	Screw
10566	2	P413314	Set Screw
10571	1	P413319	Set Screw
10766	1	P413466	Set Screw
12418	4	P413531	Cover Screw
12421	2	P413533	Set Screw
15055	1	P413571	Screw
17063	1	P413641	Collar
18065	1	P413699	Screw
31118	1	P413735	Coupling Drive Shaft Bushing
35516	1	P413762	Stitch Width Regulator Arm
35517	1	P413763	Support Shaft
35518	1	P413764	Support Shaft Bushing
35521	1	P413767	Stitch Width Indicator
35525	1	P413771	Stitch Width Assembly Cover Plate
35528	1	P413774	Lifting Crank
35529	2	P413775	Bearing Pin Connecting Bracket
35530	1	P413776	Bearing Pin, Long
35531	1	P413777	Bearing Pin, Short
35532	1	P413778	Stitch Width Regulator Connecting Arm
35533	1	P413779	Coupling Drive Shaft
90003	1	P413017	Collar
90004	1	P840405	Screw
90005	1	P413018	Magnet
90006	1	P614025	Stitch Width Limit Sensor Assembly
90007	1	P840401	Screw
90008	1	P840715	Nut
90009	1	P312013	Coupling

NOTES

From the library of: Diamond Needle Corp